

## Damage Occurrence in Welded Structures of the Bucket-Wheel Boom

Miodrag Arsić<sup>1,a</sup>, Željko Flajs<sup>1,b</sup>, Aleksandar Sedmak<sup>2,c</sup>, Emil Veg<sup>2,d</sup>,  
Simon Sedmak<sup>\*3,e</sup>

<sup>1</sup>Institute for Materials Testing, Bulevar Vojvode Mišića 43, Belgrade, Serbia

<sup>2</sup>Faculty of Mechanical Engineering, University of Belgrade, Kraljice Marije 16, 11120 Belgrade, Serbia

<sup>3</sup>Innovation Center of the Faculty of Mechanical Engineering, Kraljice Marije 16, 11120 Belgrade, Serbia

<sup>a</sup>miodrag.arsic@institutims.rs, <sup>b</sup>zeljko.flajs@institutimas.rs, <sup>c</sup>asedmak@mas.bg.ac.rs,  
<sup>d</sup>eveg@mas.bg.ac.rs, <sup>\*e</sup>simon.sedmak@yahoo.com

**Keywords:** bucket-wheel excavator boom, damage, NDT, tensometry

**Abstract.** Causes of damage occurrence in vital components of welded structures of the bucket-wheel excavator boom (DU1) at the coal landfill of the thermal power plant 'Nikola Tesla A' in Obrenovac (Serbia) are investigated. Bucket-wheel excavator was produced by French company 'Ameco' and it moves along the circular track. Taking into account lack of technical documentation, all tests and were carried out under the assumption that welded structures were made of structural steels S355 and S235. Investigation of causes of damage occurrence are based on results of non-destructive tests (NDT) and tensometric measurements.

### Introduction

There are 2 bucket-wheel excavators at the coal landfill of the thermal power plant 'Nikola Tesla A' in Obrenovac (Serbia), designated by DU1 and DU2, and produced in France. These bucket-wheel excavators move along the circular track (widely known as polar track). Taking into account the long period of operation under severe working conditions (dynamic loading with varying amplitudes), as well as the fact that during their design there were practically no possibilities to carry out the detailed stress – strain analysis, the most loaded elements and their connections have to be checked continuously [1-12]. This especially refers to welded joints and welded structures [3,4,7,8].

Bucket-wheel excavator with designation DU1 is presented in figure 1. Considering the fact that there was no technical documentation, all tests and researches presented in this paper were carried out under the assumption that welded structures were made of structural steels S355 and S235 [13].



Figure 1. Bucket-wheel excavator DU1 at the coal landfill of the thermal power plant 'Nikola Tesla A'

**Damages at Vital Sections of the Welded Lattice Structure of the Bucket-Wheel Boom**

Damage was detected mainly through visual testing (VT) of parent material and welded joints. No defects were detected with other non-destructive testing methods, as well as no deviations from expected results during hardness testing. In figure 2 the reinforcements in the damaged support structure of the cylinder, which role is to enable the moving of the bucket-wheel boom, are shown, while in figure 3 the reinforcements that were embedded in the damaged section of one of the vital girders of the structure are shown. Sections of the vital structure in the upper zone of the bucket-wheel boom with damage in the area of welded joints are shown in figure 4.

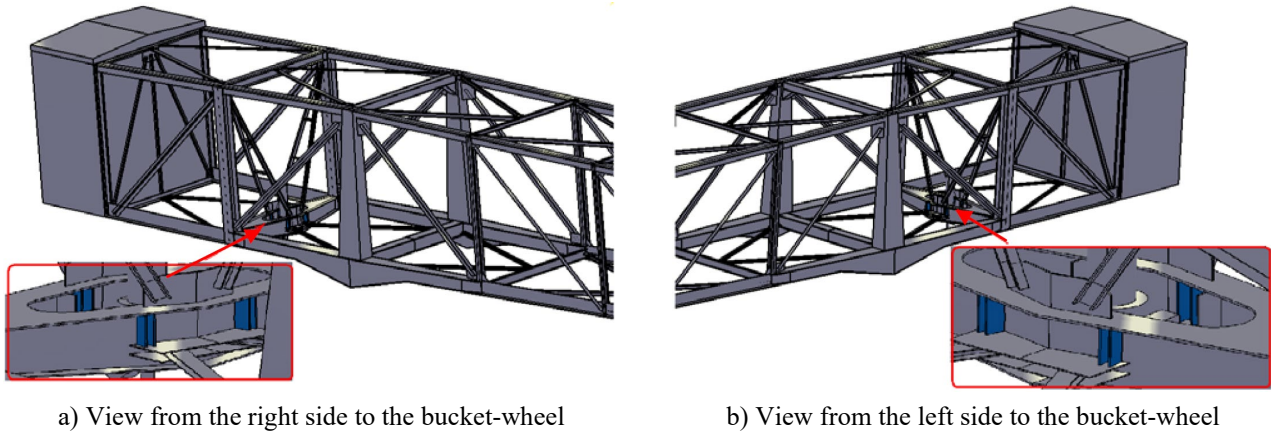

Figure 2. Reinforcements (blue) embedded in the damaged structure of the cylinder

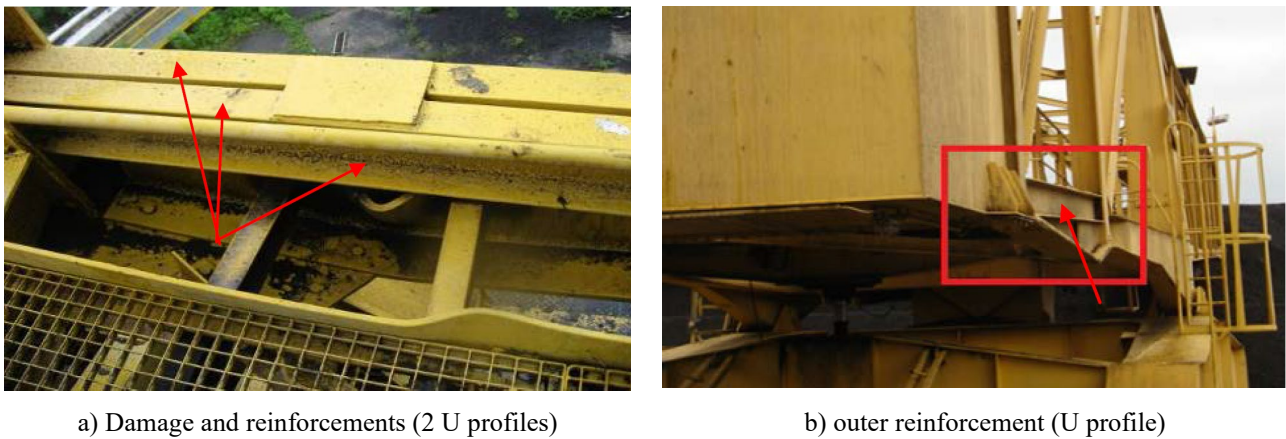

Figure 3. Reinforcements embedded in the damaged section of a vital girder at the boom structure

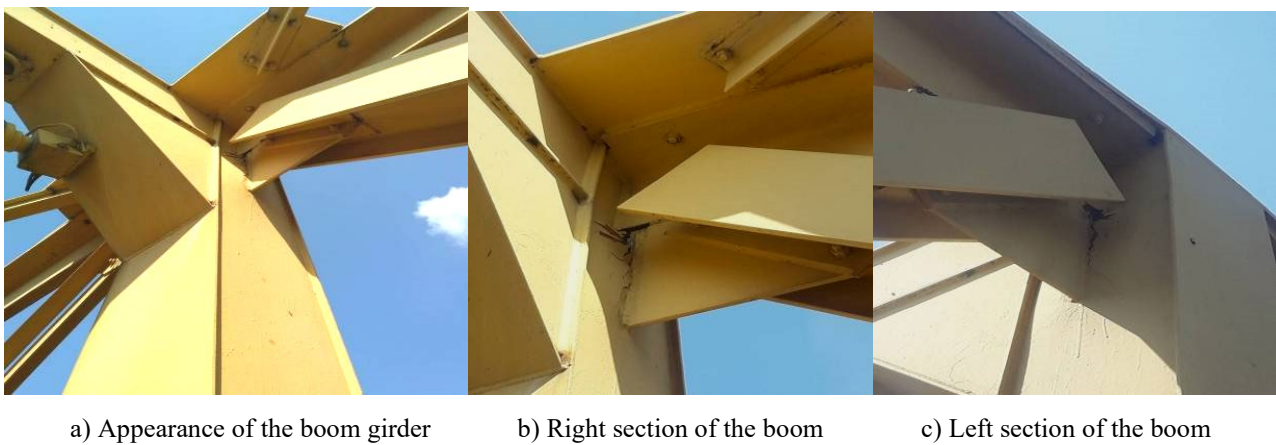

Figure 4. Sections at the vital structure of the upper zone of the bucket-wheel boom of the excavator DU1



### Stress state of Vital Structures of Bucket-Wheel Boom Based on Measured Local Strains

Stresses were determined on the basis of tensometric measurements of local strains in the areas of parent material and welded joints at the lattice structure of the bucket-wheel boom of the excavator with designation DU1. Measurements were executed through the use of electro-resistant extensometers – measurement gauges TML PL-10 and TML PL-20. Measurement equipment for detection and processing of signals from measurement gauges to readable strain values is shown in figure 5.

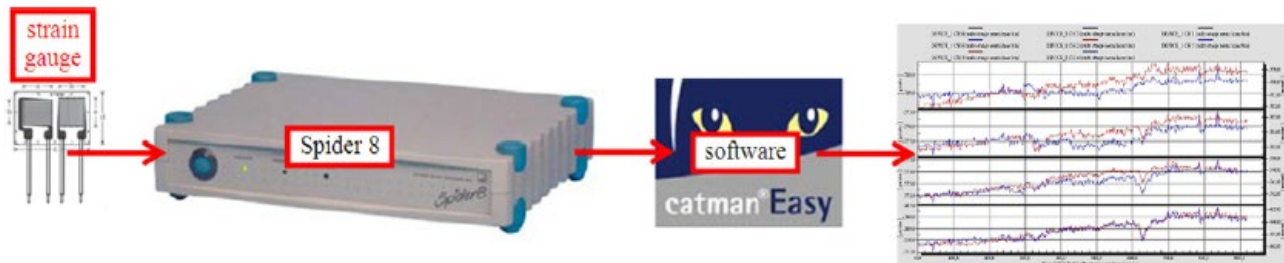

Figure 5. Measurement equipment for registration and processing of electric signals

### Cylinder and Support Structure

Stresses were calculated on the basis of tensometric measurements of local strains in different positions of the bucket-wheel boom during the operation of the bucket-wheel excavator DU1 (figure 1), in order to check if there is a possibility of appearance of initial cracks due to fatigue that occurs at vital structures of the cylinder, which enables the movement of the bucket-wheel boom. Measurements were carried out through the use of a large number of measurement gauges TML PL-20. Certain number of measurement locations at damaged vital structure in the area of the cylinder and at the support structure of the cylinder itself are presented in figures 6 and 7. On the basis of results of measured local strains and calculated stresses it was determined that the above-mentioned structures are subjected to the highest variable stresses, when bucket-wheel excavator DU1 is in the lowest position of exploitation. Allowable tensile stresses for structural steels S235 and S355 for safety level  $S=1.5$  are  $TS_{all} = 157$  [MPa] and  $TS_{all} = 237$  [MPa] respectively, with note that compressive stresses do not have the same effect on the propagation of the initial crack and structural integrity.



Figure 6. Measurement locations at the vital structure in the area of the cylinder which enables the movement of the bucket-wheel boom



a) Measurement locations right of the support structure

b) Measurement locations left of support structure

Figure 7. Measurement locations at the support structure of the cylinder

**Vital Structure of the Bucket-Wheel Boom**

Stresses have been calculated in order to check if there is a possibility of occurrence of initial cracks due to fatigue at the vital structures of the cylinder, which enables the movement of the bucket-wheel boom, on the basis of tensometric measurements of strains at the vital section of the structure for two positions of the boom ( $0^\circ$  and  $12.5^\circ$ ) during the operation of the bucket-wheel excavator DU1. Measurements have been carried out through the use of a large number of measurement gauges TML PL-10. Measurement areas and measurement locations at the vital lattice structure of the bucket-wheel boom, which is an integral part of excavator DU1 are presented in figures 8-10. Results of stresses calculated on the basis of measured strains are presented in tables 1–3, where maximum values are marked in red and bold.

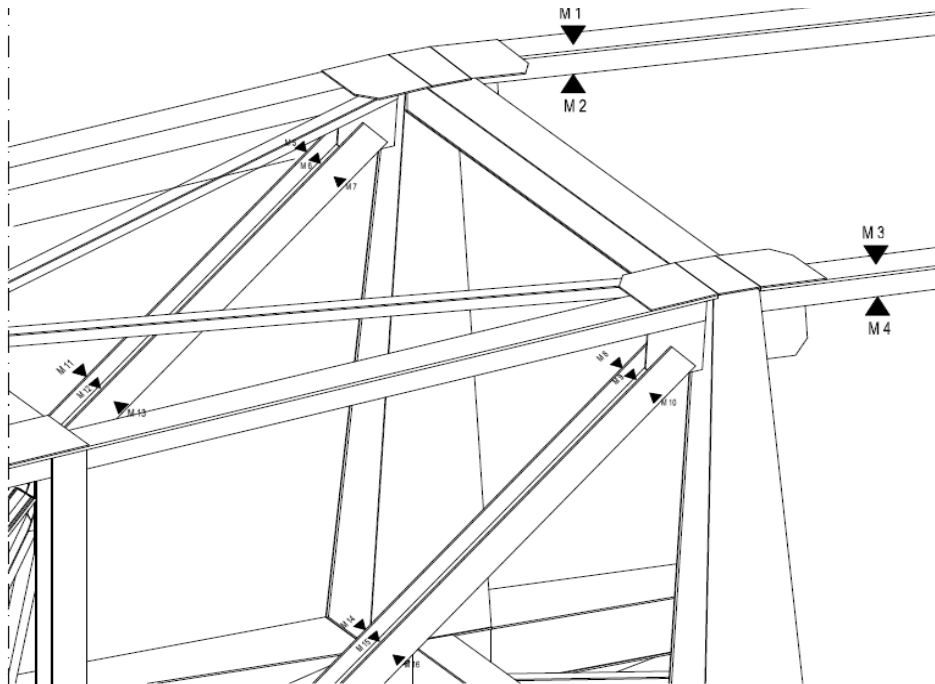
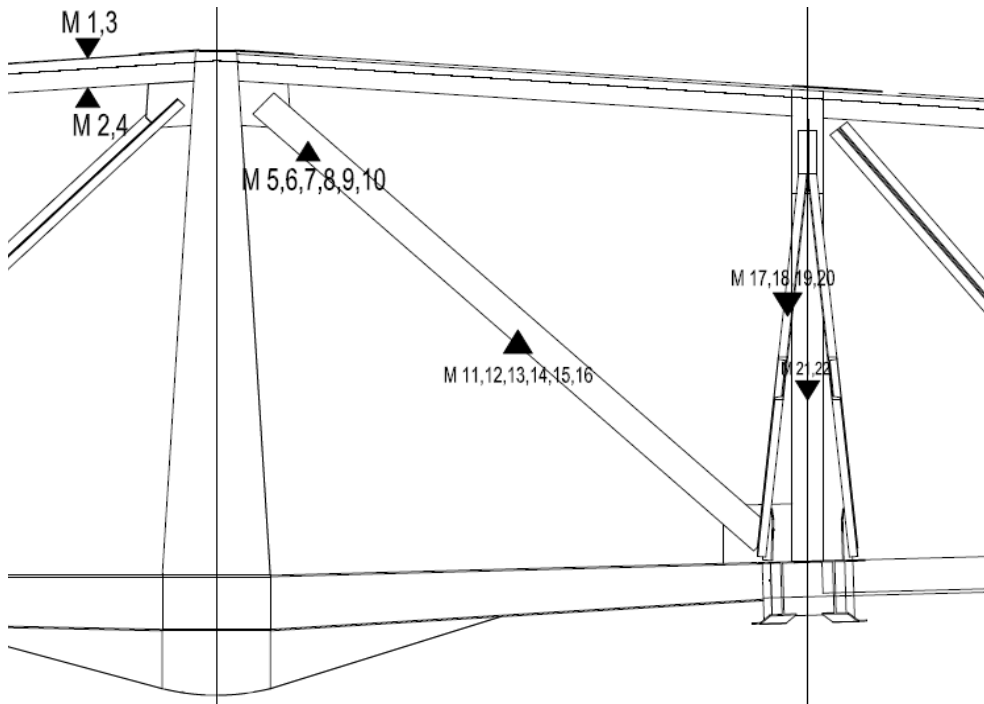

Figure 8. Measurement locations at the vital structures of the bucket-wheel boom



Cross-section 0 (position 11, figure 6)

Cross-section 11 (position 11, figure 6)

Figure 9. Measurement locations at the vital structures of the bucket-wheel boom

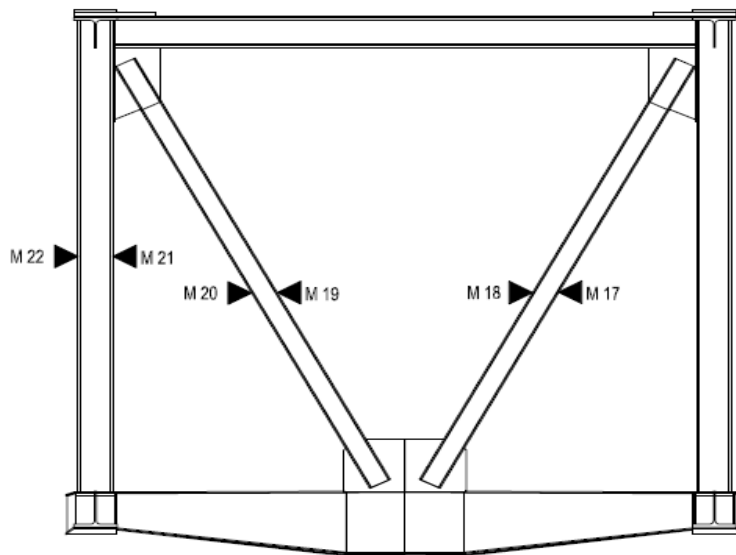

Figure 10. Measurement locations at the vital structures of the bucket-wheel boom (cross-section 11)

Table 1. Stresses at the vital structure of bucket-wheel boom (cross-section 0, Fig. 8), maximum values marked in bold

Loads at the bucket-wheel excavator DU1	Measurement locations							
	M <sub>1</sub>	M <sub>2</sub>	M <sub>3</sub>	M <sub>4</sub>	M <sub>5</sub>	M <sub>6</sub>	M <sub>7</sub>	M <sub>8</sub>
$\sigma_D$ - Measured stress for boom position at 0°, MPa	-	-	15.2	16.0	<b>32.8</b>	32.4	31.2	31.2
$\sigma_D$ - Measured stress for boom position at 12°30', MPa	-	-	<b>28</b>	19.0	21.2	22	19.2	17.2

Table 2. Stresses at the vital structure of bucket-wheel boom (cross-section 0, Fig. 9), maximum values marked in bold

Loads at the bucket-wheel excavator DU1	Measurement locations							
	M <sub>9</sub>	M <sub>10</sub>	M <sub>11</sub>	M <sub>12</sub>	M <sub>13</sub>	M <sub>14</sub>	M <sub>15</sub>	M <sub>16</sub>
$\sigma_D$ - Measured stress for boom position at 0°, MPa	<b>32.8</b>	27.6	31.2	30.8	28.4	27.2	30.0	29.6
$\sigma_D$ - Measured stress for boom position at 12°30', MPa	<b>20.4</b>	18.0	20.0	19.2	18.0	19.2	16.8	16.4

Table 3. Stresses at the vital structure of bucket-wheel boom (cross-section 11, Fig. 10), maximum values marked in bold

Loads at the bucket-wheel excavator DU1	Measurement locations					
	M <sub>17</sub>	M <sub>18</sub>	M <sub>19</sub>	M <sub>20</sub>	M <sub>21</sub>	M <sub>22</sub>
$\sigma_D$ - Measured stress for boom position at 0°, MPa	41.2	<b>44.4</b>	<b>44.4</b>	41.2	20.4	20.4
$\sigma_D$ - Measured stress for boom position at 12°30', MPa	<b>31.2</b>	31.2	30.0	30.4	12.0	12.4

**Analysis of Causes of Damage in Vital Components of the Bucket-Wheel Boom**

Based on the analysis of results of non-destructive tests executed at vital structures of the bucket-wheel boom, it can be concluded that initial cracks within welded joints can propagate until they reach the critical length, which confirms the assumption that damages at vital structures occurred due to inadequate welding technologies during the manufacture of the bucket-wheel excavator and/or during previous repairs performed on parent material and welded joints, figures 2-4. Significant presence of defects in the area of welded joints, figure 4, is caused by complex geometry, figure 11.

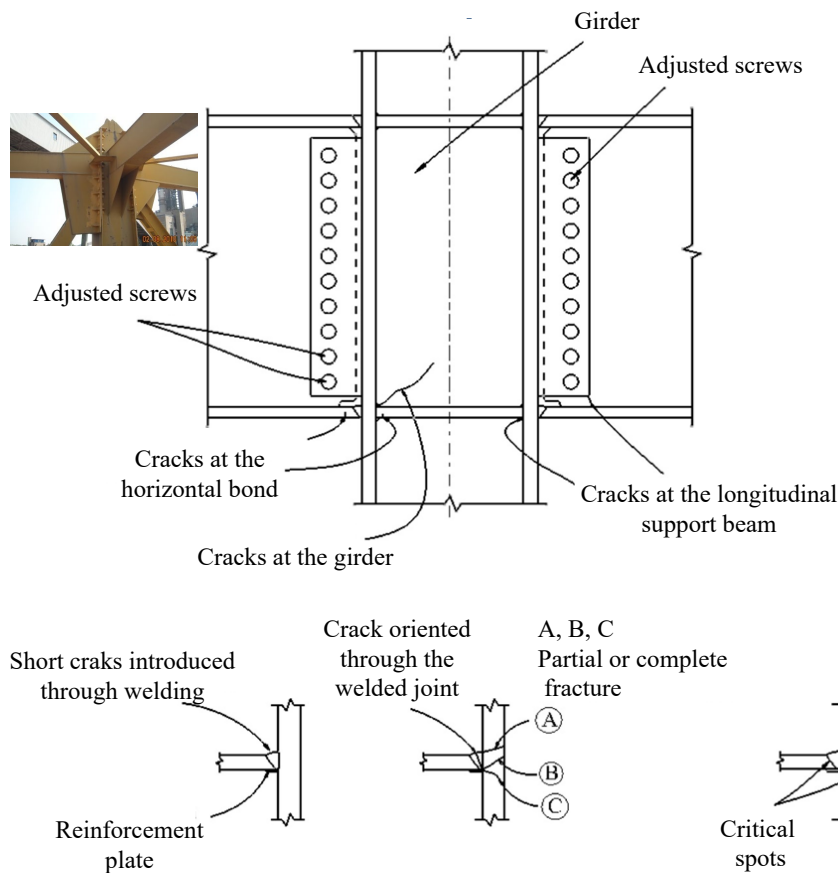

Figure 11. Node at the welded structure and locations at which fatigue cracks mainly occur

In accordance with recommendations [14], it was adopted that critical value of fatigue safety is  $\sigma_{Dwj} = 45$  MPa. Tensile strength of the weld metal is determined by the following expressions [15]:

$$\sigma_{TSWj235} = 0.5\sigma_{UTSwj} + 0.5\sigma_{UTS} \tag{1.1}$$

$$\sigma_{TSWj235} = 0.5 \times 510 + 0.5 \times 370 \tag{1.2}$$

$$\sigma_{TSWj235} = 440 \text{ MPa} \tag{1.3}$$

$$\sigma_{TSWj355} = 0.5\sigma_{UTSwj} + 0.5\sigma_{UTS} \tag{2.1}$$

$$\sigma_{TSWj355} = 0.5 \times 510 + 0.5 \times 520 \tag{2.2}$$

$$\sigma_{TSWj355} = 515 \text{ MPa} \tag{2.3}$$



where:

$\sigma_{UTS_{wj}} = 510$  MPa – minimum tensile strength of filler material (electrode EVB 50),

$\sigma_{UTS} = 370$  MPa – minimum tensile strength of parent material S 235, [13],

$\sigma_{UTS} = 520$  MPa – minimum tensile strength of parent material S 355, [13].

It is obvious that in both representative combinations of static stresses (figure 12), measured stresses in critical areas of vital components of the bucket-wheel (tables 1-3) lie beneath the limit line which connects fatigue strength  $\sigma_{Dwj}$  and tensile strength  $\sigma_{UTSmin}$  of weld metal, which proves that damages at vital components of welded lattice structure of the bucket-wheel boom occurred due to the application of inadequate welding technologies during the manufacture of the bucket-wheel excavator and/or during the previous repairs.

One should notice that stresses, calculated here on the basis measured strains, are in good agreement with the numerical results, obtaining by the FEM, as shown in [16].

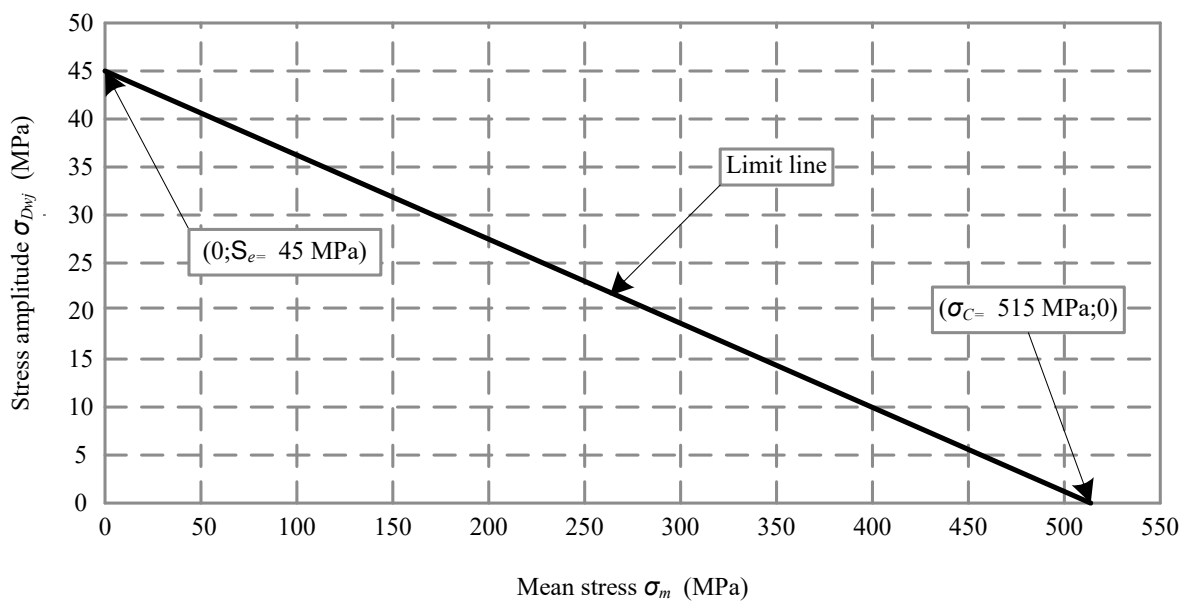

Fig. 12. Modified Goodman diagram

## Conclusion

Results of tensometric measurements showed that welded structure of the bucket-wheel boom was designed in complete agreement with its function and operational loads with low service stresses which could not produce damage shown in this investigation. Therefore, it is clear that damage at vital components of welded lattice structure of the bucket-wheel boom occurred due to the application of inadequate welding processes and/or procedures during the manufacture and/or during the previous repairs.

## Acknowledgements

This work was supported by the Ministry of Education, Science and Technological Development of the Republic of Serbia (Contracts No. 451-03-9/2021-14/200012, 451-03-9/2021-14/200105 and 451-03-9/2021 -14/200213).

---

**References**

- [1] S. Sedmak, A. Sedmak, M. Arsić, J. Tuma, An Experimental Verification of Numerical Models for the Fracture and Fatigue of Welded Structures, *Materials and technology*, 41 (2007) 173-178.
- [2] M. Arsić, M. Mladenović, A. Veljović, M. Rakin, Z. Radaković, Reliability of Critical Welded Joints in Responsible Support Structures of Bucket Wheel Excavator, XIX International Conference on Material handling, constructions and logistics – MHCL '09, Belgrade, 2009, 133-138.
- [3] S. Bošnjak, N. Zrnić, A. Simonović, D. Momčilović, Failure analysis of the end eye connection of the bucket wheel excavator portal tie-rod support, *Engineering Failure Analysis*, 16 (2009) 740-50.
- [4] E. Rusiński, J. Czmochowski, A. Iluk, M. Kowalczyk, An analysis of the causes of a BWE counterweight boom support fracture, *Engineering Failure Analysis*, 17 (2010) 179-91.
- [5] M. Arsić, S. Bošnjak, N. Zrnić, A. Sedmak, N. Gnjatović, Bucket wheel failure caused by residual stresses in welded joints, *Engineering Failure Analysis*, 18 (2011) 700-712
- [6] S. Bošnjak, M. Arsić, N. Zrnić, M. Rakin, M. Pantelic, Bucket wheel excavator: Integrity assessment of the bucket wheel boom tie-rod welded joint, *Engineering Failure Analysis*, 18 (2011) 212-222.
- [7] M. Savković, M. Gašić, M. Arsić, R. Petrović, Analysis of the axle fracture of the bucket wheel excavator, *Engineering Failure Analysis*, 18 (2011) 433-441.
- [8] D. Arsić, N. Gnjatović, S. Simon, A. Arsić, M. Uhnčak, Integrity Assessment and Determination of Residual Fatigue Life of Vital Parts of Bucket-Wheel Excavator Operating Under Dynamic Loads, *Engineering Failure Analysis*, 105 (2019) 182-195.
- [9] D. Danicic, S. Sedmak, I. Blacic, S. Kirin, Scenario of fracture development in bucket wheel excavator, *Structural integrity and life*, 13 (2013) 189–196
- [10] S. Kirin, M. Božic, M. Brzakovic, I. Vucetic, Challenges of future research in the area of industrial safety. *Structural integrity and life*, 15 (2015) 71-78.
- [11] S. Kirin, P. Stanojevic, I. Miljanovic, A. Sedmak, T. Peric, P. Ilic, Influence of the human factor on risks in an open-pit mine, *Structural integrity and life*, 15 (2015), 117–128
- [12] S. Bošnjak, Z. Petković, P. Matejić, N. Zrnić, S. Petrić, A. Simonović, Analysis of Stress-Strain State of Bucket Wheel Excavator Revolving Platform Structure – Fundament of Efficient Reconstruction, *Structural Integrity and Life*, 5 (2005) 129–142
- [13] EN 10025-2: Hot rolled products of structural steels - Part 2: Technical delivery conditions for non-alloy structural steels, European Committee Standardization, 2004.
- [14] A.F. Hobbacher, Recommendations for fatigue design of welded joints and components. IIW Document XIII-2151r3-07/XV-1254r3-07. International Institute of Welding; 2008.
- [15] B.G. Mellor, R.C.T. Rainey, N.E. Kirk, The static strength of end and T fillet weld connections. *Materials & Design*, 20 (1999) 193-205.
- [16] M. Arsić, Ž. Flajš, A. Sedmak, E. Veg, S. Sedmak, Structural integrity assessment and repair of welded structures of the bucket-wheel boom, *Structural Integrity and Life*, 21 (2021) 201-206